

DESCRIPTION: MALE - DIP SOLDER / MACHINED - PREMIUM

DIMENSIONS(mm)							
SIZE	A ^{±.36}	B ^{±.10}	C ^{±.15}	D ^{±.15}	E ^{±.38}	F ^{±.25}	G ^{±.25}
9	30.80	24.99	17.00	8.40	19.20	12.60	10.90
15	39.15	33.32	25.30	8.40	27.70	12.60	10.90
25	53.04	47.04	39.00	8.40	41.10	12.60	10.90
37	69.32	63.50	55.40	8.40	57.30	12.60	10.90
50	66.93	61.11	52.80	11.10	55.10	15.20	13.60

MATERIAL:

SHELL: STEEL, NICKEL PLATED
 INSULATOR: PA6T, UL94 V-0
 PROCESS TEMP.: 260°C
 CONTACT: BRASS (FLOATING CONTACTS)

ELECTRICAL:

CURRENT RATING: 5 AMPS
 CONTACT RESISTANCE: 15 mOhms Max.
 INSULATION RESISTANCE: 1,000 MOhms Min.
 VOLTAGE: 500VAC FOR 1 MINUTE
 TEMPERATURE: -50° C TO 100° C

172-YYY-113RYY1

SERIES _____
 POSITIONS _____
 009
 015
 025
 037
 050
 GENDER _____
 1 = MALE
 TERMINATION _____
 1 = DIP SOLDER
 SHELL PLATING _____
 3 = NICKEL (GROUND INDENTS)
 HARDWARE OPTIONS _____
 00 = NO HARDWARE
 01 = .065" NUT (PCB SIDE)
 02 = .250" NUT (PCB SIDE)
 03 = .250" NUT (MATING SIDE)
 05 = .237" 4-40 BOARD LOCK
 90 = .237" 4-40 BOARD LOCK
 FOR 0.093" BOARD MAX.
 91 = .237" 4-40 SPACER/ BOARD LOCK
 92 = .237" 4-40 SPACER/ BOARD LOCK
 FOR 0.093" BOARD MAX.
 PLATING OPTIONS _____
 1 = GOLD FLASH
 2 = 30MICRO-INCH GOLD

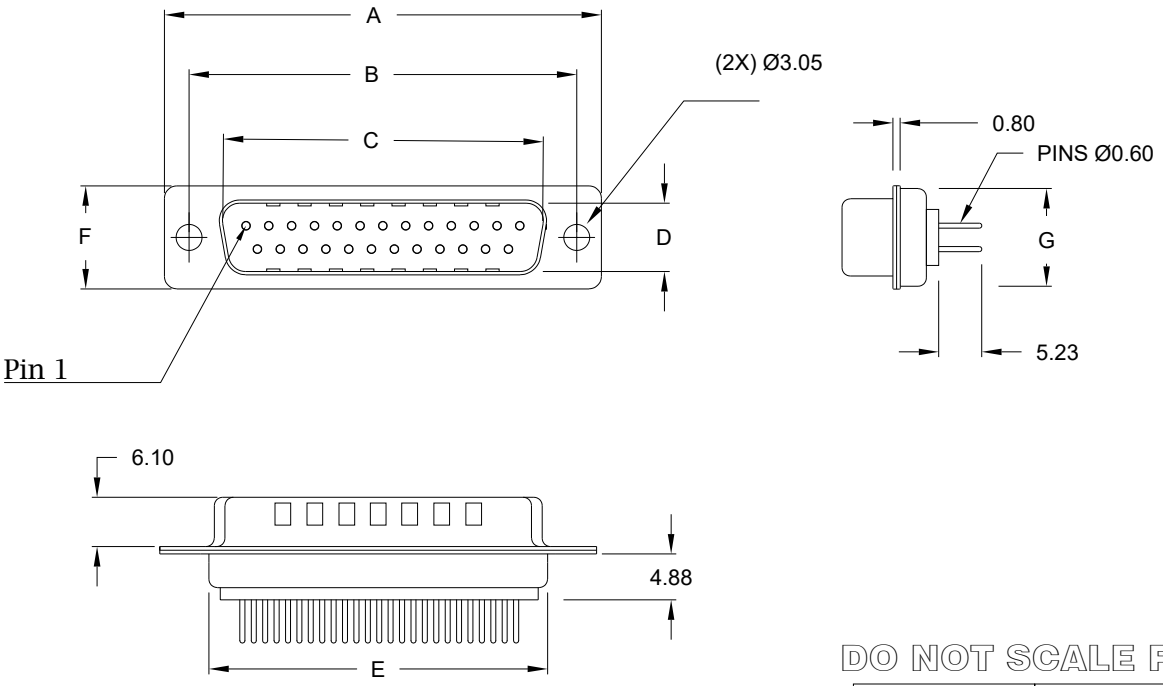

DO NOT SCALE FROM DRAWING

UNITS = mm

 <p>THESE DRAWINGS AND SPECIFICATIONS ARE THE PROPERTY OF NorComp AND SHALL NOT BE REPRODUCED, COPIED OR USED AS THE BASIS FOR THE MANUFACTURE OF SALE OF APPARATUS WITHOUT WRITTEN PERMISSION.</p>	DRAWN: PAM JENKINS	DATE: 09-12-05	
	SCALE: NTS	SHEET 1 OF 3	REV 20
	DWG NO. 172-YYY-113RYY1		

NorComp

RoHS COMPLIANT

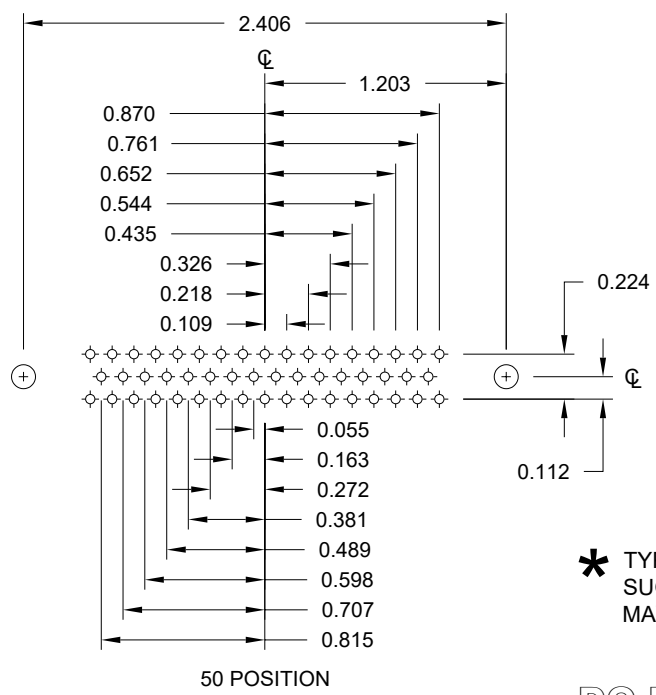
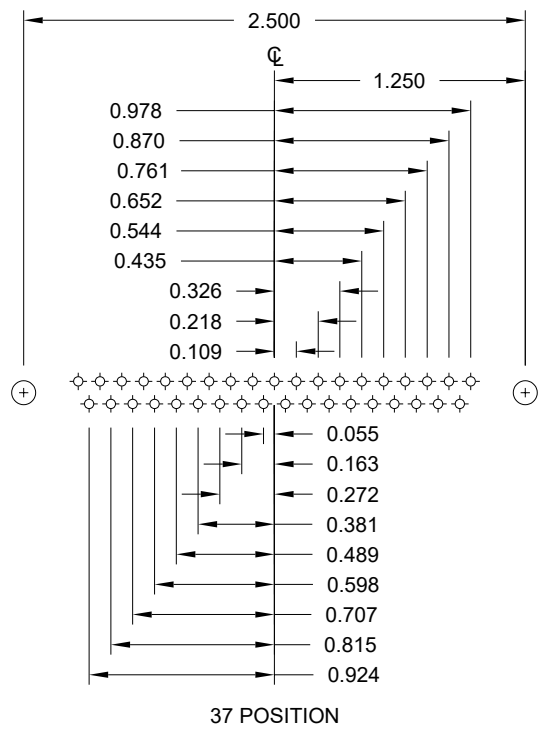
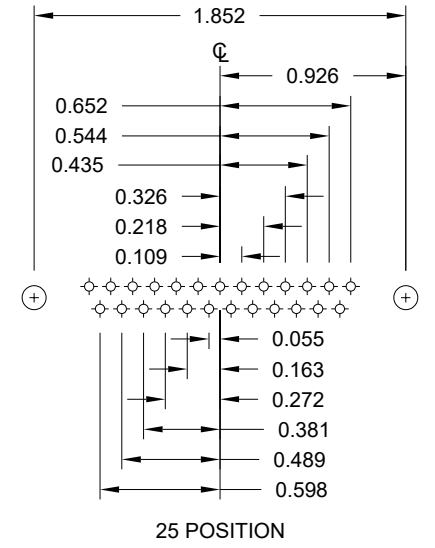
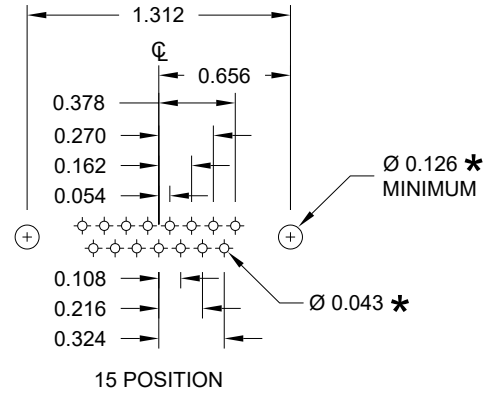
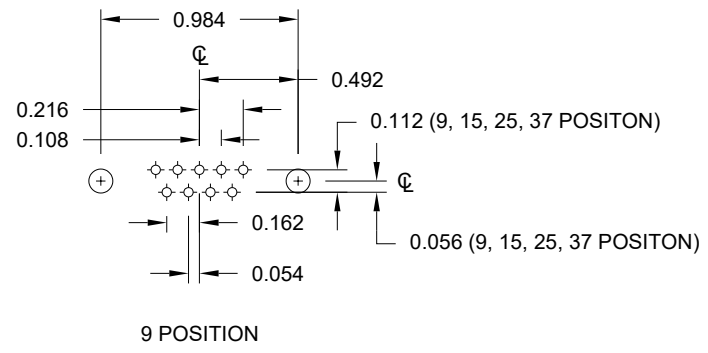

UNITS = inch
 * TYP. SUGGESTED SIZE MAY NOT BE SUITABLE FOR ALL APPLICATIONS

DO NOT SCALE FROM DRAWING

	THESE DRAWINGS AND SPECIFICATIONS ARE THE PROPERTY OF NorComp AND SHALL NOT BE REPRODUCED, COPIED OR USED AS THE BASIS FOR THE MANUFACTURE OF SALE OF APPARATUS WITHOUT WRITTEN PERMISSION.		DRAWN: PAM JENKINS	DATE: 09-12-05
	NorComp		SCALE: NTS	SHEET OF 2 3
DWG NO. 172-YYY-113RYY1				

DESCRIPTION: CLINCH NUT HARDWARE

TOLERANCE:
 ALL DIMENSIONS ARE ±0.010
 UNLESS OTHERWISE
 SPECIFIED

ALL CLINCH-NUTS ARE 4-40 INTERNAL THREADS

****NOTE: 90 & 92 OPTION FOR 0.093" MAX. BOARD THICKNESS**

"01" // PCB SIDE

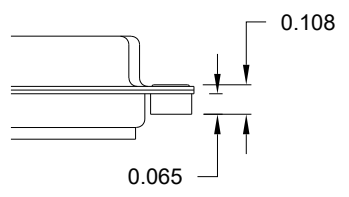

"02" // PCB SIDE

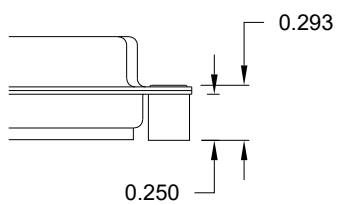

"03" // MATING SIDE

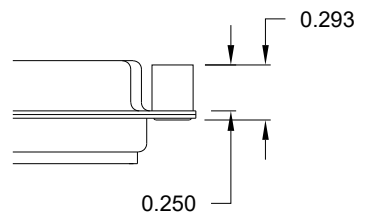

"05" // PCB SIDE

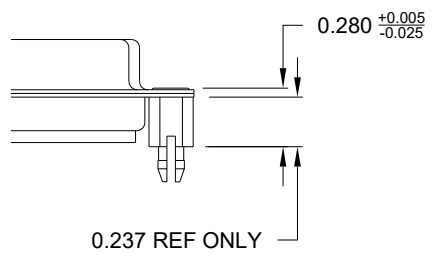

"91" // PCB SIDE

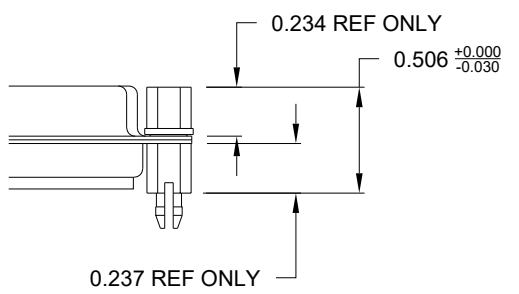

"90" // PCB SIDE **

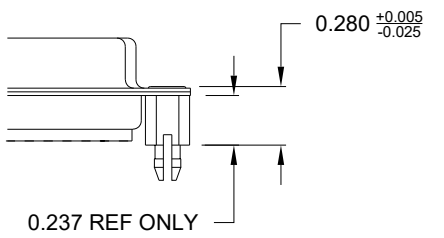

NOTE: 4-40 FEMALE SCREW LOCK IS REMOVABLE

"92" // PCB SIDE **

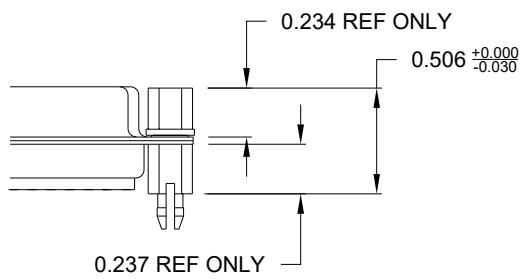

UNITS = inch

DO NOT SCALE FROM DRAWING

RoHS COMPLIANT

	THESE DRAWINGS AND SPECIFICATIONS ARE THE PROPERTY OF NorComp AND SHALL NOT BE REPRODUCED, COPIED OR USED AS THE BASIS FOR THE MANUFACTURE OF SALE OF APPARATUS WITHOUT WRITTEN PERMISSION.		DRAWN: PAM JENKINS	DATE: 09-12-05	
	NorComp		SCALE: NTS	SHEET 3 OF 3	REV 20
			DWG NO. 172-YYY-113RYY1		